

ADD3501 3½ Digit DVM with Multiplexed 7-Segment Output

General Description

The ADD3501 monolithic DVM circuit is manufactured using standard complementary MOS (CMOS) technology. A pulse modulation analog-to-digital conversion technique is used and requires no external precision components. In addition, this technique allows the use of a reference voltage that is the same polarity as the input voltage.

One 5V (TTL) power supply is required. Operating with an isolated supply allows the conversion of positive as well as negative voltages. The sign of the input voltage is automatically determined and output on the sign pin. If the power supply is not isolated, only one polarity of voltage may be converted.

The conversion rate is set by an internal oscillator. The frequency of the oscillator can be set by an external RC network or the oscillator can be driven from an external frequency source. When using the external RC network, a square wave output is available. It is important to note that great care has been taken to synchronize digit multiplexing with the A/D conversion timing to eliminate noise due to power supply transients.

The ADD3501 has been designed to drive 7-segment multiplexed LED displays directly with the aid of external digit buffers and segment resistors. Under condition of over-range, the overflow output will go high and the display will read +OFL or -OFL, depending on whether the input voltage is positive or negative. In addition to this, the most significant digit is blanked when zero.

A start conversion input and a conversion complete output are included on all 4 versions of this product.

Features

- Operates from single 5V supply
- Converts 0V to ±1.999V
- Multiplexed 7-segment
- Drives segments directly
- No external precision component necessary
- Accuracy specified over temperature
- Medium speed - 200ms/conversion
- Internal clock set with RC network or driven externally
- Overrange Indicated by +OFL or -OFL display reading and OFLO output
- Analog inputs in applications shown can withstand ±200 Volts
- ADD3501 equivalent to MM74C935

Applications

- Low cost digital power supply readouts
- Low cost digital multimeters
- Low cost digital panel meters
- Eliminate analog multiplexing by using remote A/D converters
- Convert analog transducers (temperature, pressure, displacement, etc.) to digital transducers

Connection Diagram

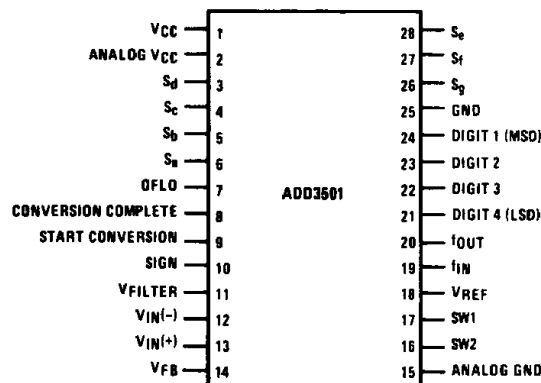

Order Number ADD3501CCN
See NS Package Number N28B

TL/H/5681-1

Absolute Maximum Ratings (Note 1)

If Military/Aerospace specified devices are required, please contact the National Semiconductor Sales Office/Distributors for availability and specifications.

Voltage at Any Pin	-0.3V to $V_{CC} + 0.3V$
Operating Temperature Range (T_A)	-40°C to +85°C
ESD Susceptibility (Note 3)	TBDV

Package Dissipation at $T_A = 25^\circ\text{C}$	800 mW
derate at $\theta_{JA(\text{MAX})} = 125^\circ\text{C/Watt}$	
above $T_A = 25^\circ\text{C}$	
Operating V_{CC} Range	4.5V to 6.0V
Absolute Maximum V_{CC}	6.5V
Lead Temp. (Soldering, 10 seconds)	260°C
Storage Temperature Range	-65°C to +150°C

Electrical Characteristics ADD3501

$4.75V \leq V_{CC} \leq 5.25V$, $-40^\circ\text{C} \leq T_A \leq +85^\circ\text{C}$, unless otherwise specified.

Symbol	Parameter	Conditions	Min	Typ(2)	Max	Units
$V_{IN(1)}$	Logical "1" Input Voltage		$V_{CC} - 1.5$			V
$V_{IN(0)}$	Logical "0" Input Voltage				1.5	V
$V_{OUT(0)}$	Logical "0" Output Voltage (All Digital Outputs except Digit Outputs)	$I_O = 1.1 \text{ mA}$			0.4	V
$V_{OUT(0)}$	Logical "0" Output Voltage (Digit Outputs)	$I_O = 0.7 \text{ mA}$			0.4	V
$V_{OUT(1)}$	Logical "1" Output Voltage (All Segment Outputs)	$I_O = 50 \text{ mA}@T_J = 25^\circ\text{C}$ $V_{CC} = 5V$ $I_O = 30 \text{ mA}@T_J = 100^\circ\text{C}$	$V_{CC} - 1.6$ $V_{CC} - 1.6$	$V_{CC} - 1.3$ $V_{CC} - 1.3$		V V
$V_{OUT(1)}$	Logical "1" Output Voltage (All Digital Outputs except Segment Outputs)	$I_O = 500 \mu\text{A}$ (Digit Outputs) $I_O = 360 \mu\text{A}$ (Conv. Complete, + / -, Oflo Outputs)	$V_{CC} - 0.4$			V
I_{SOURCE}	Output Source Current (Digit Outputs)	$V_{OUT} = 1.0V$	2.0			mA
$I_{IN(1)}$	Logical "1" Input Current (Start Conversion)	$V_{IN} = 1.5V$			1.0	μA
$I_{IN(0)}$	Logical "0" Input Current (Start Conversion)	$V_{IN} = 0V$	-1.0			μA
I_{CC}	Supply Current	Segments and Digits Open		0.5	10	mA
f_{OSC}	Oscillator Frequency			0.6/RC		kHz
f_{IN}	Clock Frequency		100		640	kHz
f_C	Conversion Rate			$f_{IN}/64,512$		conv./sec
f_{MUX}	Digit Mux Rate			$f_{IN}/256$		Hz
t_{BLANK}	Inter Digit Blanking Time			$1/(32f_{MUX})$		sec
t_{SCPW}	Start Conversion Pulse Width		200		DC	ns

Note 1: Absolute Maximum Ratings indicate limits beyond which damage to the device may occur. DC and AC electrical specifications do not apply when operating the device beyond its specified operating conditions.

Note 2: All typicals given for $T_A = 25^\circ\text{C}$.

Note 3: Human body model, 100 pF discharged through a 1.5 k Ω resistor.

Electrical Characteristics ADD3501

$t_C = 5$ conversions/second, $0^\circ\text{C} \leq T_A \leq 70^\circ\text{C}$, unless otherwise specified.

Parameter	Conditions	Min	Typ	Max	Units
Non-Linearity	$V_{IN} = 0 - 2\text{V Full Scale}$	-0.05	± 0.025	+0.05	% of full scale
	$V_{IN} = 0 - 200\text{mV Full Scale}$	-0.05	± 0.025	+0.05	% of full scale
Quantization Error		-1		+0	counts
Offset Error, $V_{IN} = 0\text{V}$		-0.5	+1.5	+3	mV
Rollover Error		-0		+0	counts
Analog Input Current (V_{IN+} , V_{IN-})	$T_A = 25^\circ\text{C}$	-5	± 0.5	+5	nA

Block Diagram

ADD3501 3 1/2-Digit DVM Block Diagram

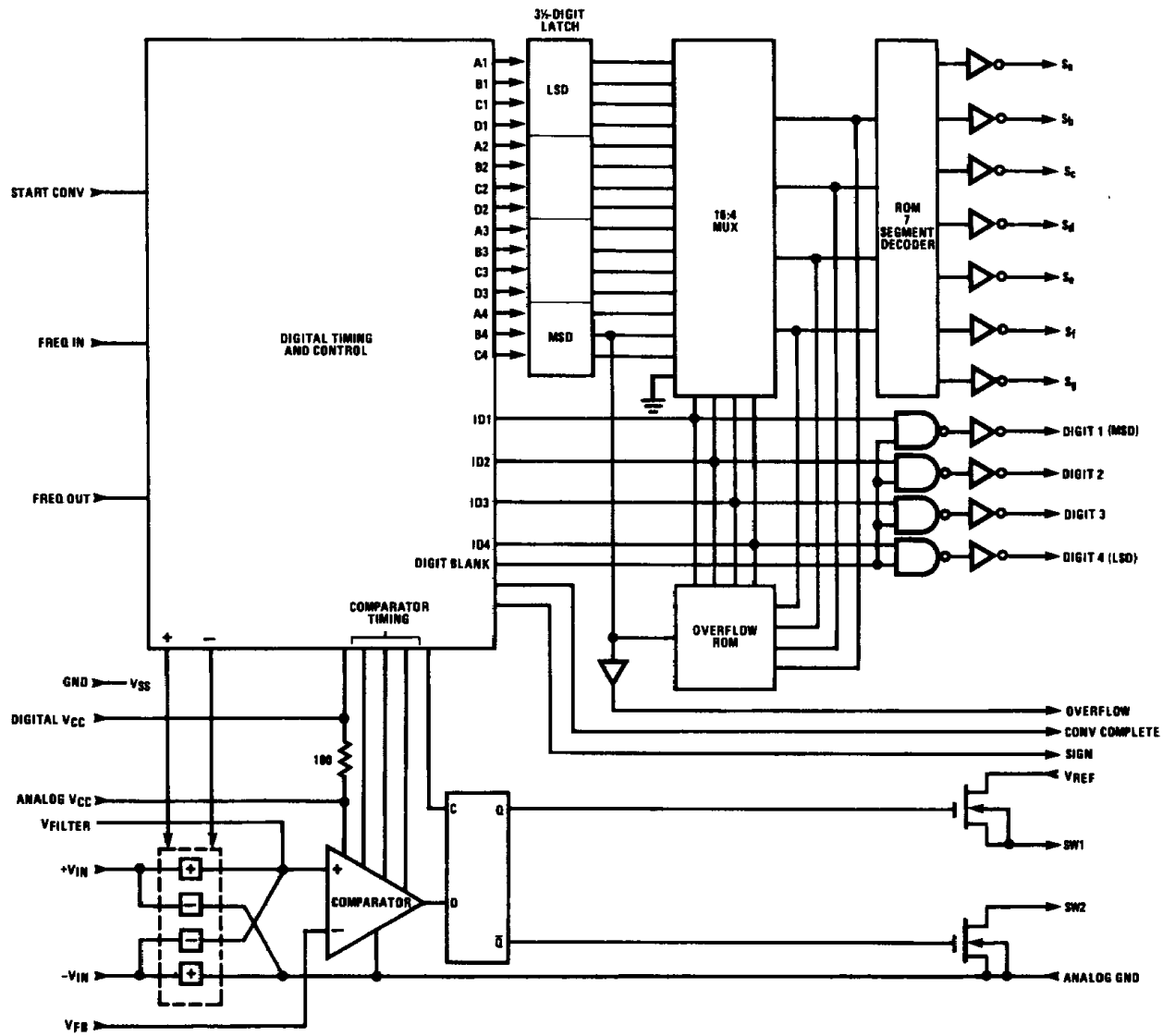

TL/H/5681-2

Theory of Operation

A schematic for the analog loop is shown in *Figure 1*. The output of SW1 is either at V_{REF} or zero volts, depending on the state of the D flip-flop. If Q is at a high level $V_{OUT} = V_{REF}$ and if Q is at a low level $V_{OUT} = 0V$. This voltage is then applied to the low pass filter comprised of R_1 and C_1 . The output of this filter, V_{FB} , is connected to the negative input of the comparator, where it is compared to the analog input voltage, V_{IN} . The output of the comparator is connected to the D input of the D flip-flop. Information is then transferred from the D input to the Q and \bar{Q} outputs on the positive edge of clock. This loop forms an oscillator whose duty cycle is precisely related to the analog input voltage, V_{IN} .

An example will demonstrate this relationship. Assume the input voltage is equal to 0.500V. If the Q output of the D flip-flop is high then V_{OUT} will equal V_{REF} (2.000V) and V_{FB} will charge toward 2V with a time constant equal to R_1C_1 . At some time V_{FB} will exceed 0.500V and the comparator output will switch to 0V. At the next clock rising edge the Q output of the D flip-flop will switch to ground, causing V_{OUT} to switch to 0V. At this time V_{FB} will start discharging toward 0V with a time constant R_1C_1 . When V_{FB} is less than 0.5V the comparator output will switch high. On the rising edge of the next clock the Q output of the D flip-flop will switch high and the process will repeat. There exists at the output of SW1 a square wave pulse train with positive amplitude V_{REF} and negative amplitude 0V.

The DC value of this pulse train is:

$$V_{OUT} = V_{REF} \left(\frac{T_{ON}}{T_{ON} + T_{OFF}} \right) = V_{REF}(\text{duty cycle})$$

Schematic Diagram

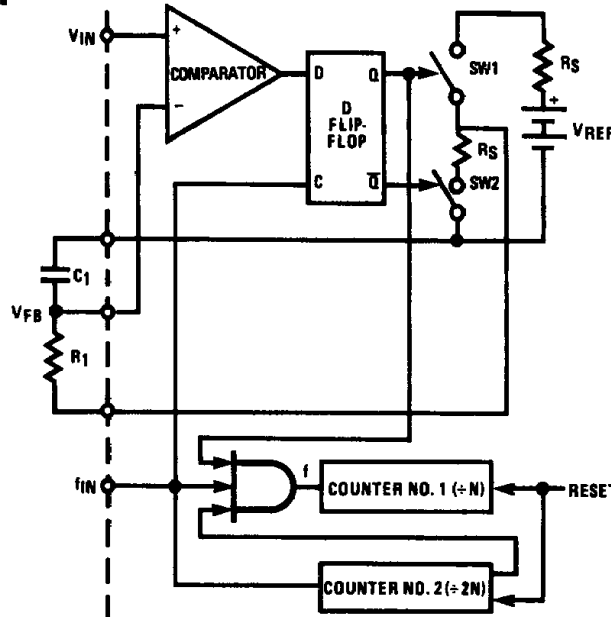

TL/H/5681-3

$$V_{IN} = V_{FB} = V_{REF} \times (\text{duty cycle})$$

$$f = (\text{duty cycle}) \times f_{IN}$$

$$\text{Count in Counter No. 1} = \frac{f}{f_{IN}/N} = \frac{(\text{duty cycle}) \times f_{IN}}{f_{IN}/N} = \frac{V_{IN}}{V_{REF}} \times N$$

**Figure 1. Analog Loop Schematic
Pulse Modulation A/D Converter**

The lowpass filter will pass the DC value and then:

$$V_{FB} = V_{REF}(\text{duty cycle})$$

Since the closed loop system will always force V_{FB} to equal V_{IN} , we can then say that:

$$V_{IN} = V_{FB} = V_{REF}(\text{duty cycle})$$

or

$$\frac{V_{IN}}{V_{REF}} = (\text{duty cycle})$$

The duty cycle is logically ANDed with the input frequency f_{IN} . The resultant frequency f equals:

$$f = (\text{duty cycle}) \times (\text{clock})$$

Frequency f is accumulated by counter no. 1 for a time determined by counter no. 2. The count contained in counter no. 1 is then:

$$\begin{aligned} (\text{count}) &= \frac{f}{(\text{clock})/N} = \frac{(\text{duty cycle}) \times (\text{clock})}{(\text{clock})/N} \\ &= \frac{V_{IN}}{V_{REF}} \times N \end{aligned}$$

For the ADD3501, $N = 2000$.

General Information

The timing diagram, shown in *Figure 2*, gives operation for the free running mode. Free running operation is obtained by connecting the Start Conversion input to logic "1" (V_{CC}). In this mode the analog input is continuously converted and the display is updated at a rate equal to $64,512 \times 1/f_{IN}$.

The rising edge of the Conversion Complete output indicates that new information has been transferred from the internal counter to the display latch. This information will remain in the display latch until the next low-to-high transition of the Conversion Complete output. A logic "1" will be maintained on the Conversion Complete output for a time equal to $64 \times 1/f_{IN}$.

Figure 3 gives the operation using the Start Conversion input. It is important to note that the Start Conversion input and Conversion Complete output do not influence the actual analog-to-digital conversion in any way.

Internally the ADD3501 is always continuously converting the analog voltage present at its inputs. The Start Conversion input is used to control the transfer of information from the internal counter to the display latch.

An RS latch on the Start Conversion input allows a broad range of input pulse widths to be used on this signal. As shown in *Figure 3*, the Conversion Complete output goes to a logic "0" on the rising edge of the Start Conversion pulse and goes to a logic "1" some time later when the new conversion is transferred from the internal counter to the display latch. Since the Start Conversion pulse can occur at any time during the conversion cycle, the amount of time from Start Conversion to Conversion Complete will vary. The maximum time is $64,512 \times 1/f_{IN}$ and the minimum time is $256 \times 1/f_{IN}$.

Timing Waveforms

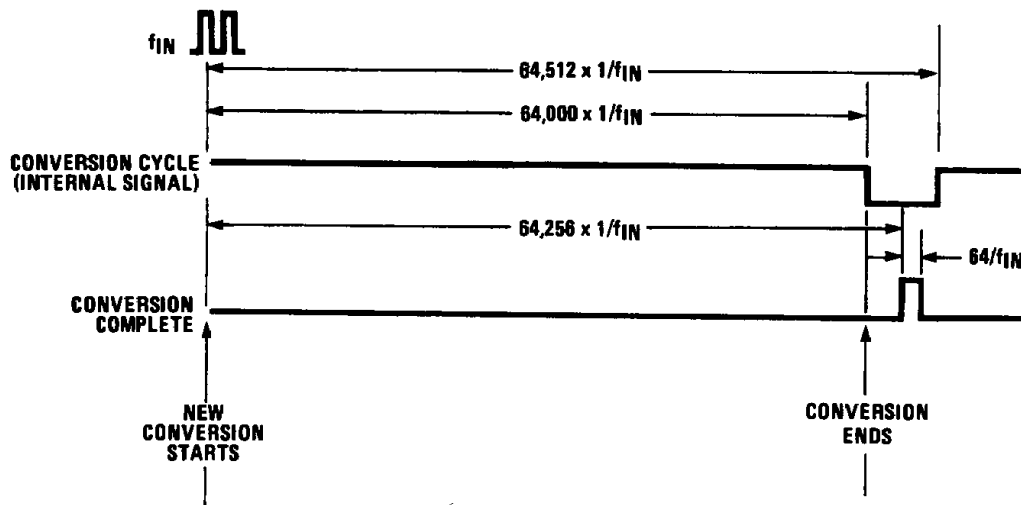

Figure 2. Conversion Cycle Timing Diagram for Free Running Operation

TL/H/5681-4

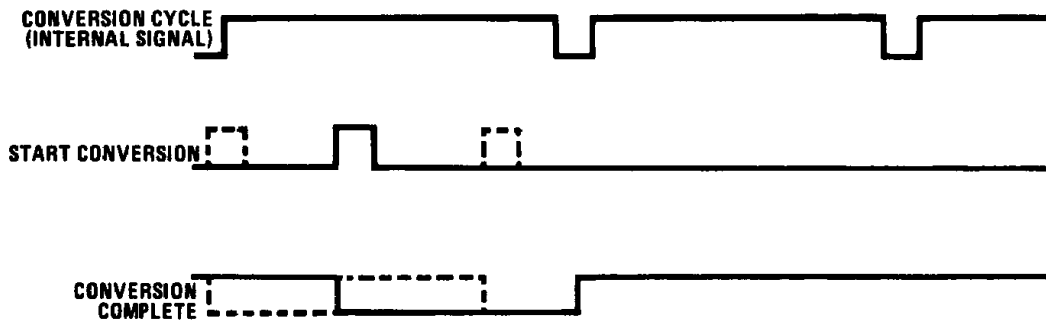

Figure 3. Conversion Cycle Timing Diagram Operating with Start Conversion Input

TL/H/5681-5

Applications

SYSTEM DESIGN CONSIDERATIONS

Perhaps the most important thing to consider when designing a system using the ADD3501 is power supply noise on the V_{CC} and ground lines. Because a single power supply is used and currents in the 300 mA range are being switched, good circuit layout techniques cannot be overemphasized. Great care has been exercised in the design of the ADD3501 to minimize these problems but poor printed circuit layout can negate these features.

Figures 4, 5, and 6 show schematics of DVM systems. An attempt has been made to show, on these schematics, the proper distribution for ground and V_{CC} . To help isolate digital and analog portions of the circuit, the analog V_{CC} and ground have been separated from the digital V_{CC} and ground. Care must be taken to eliminate high current from flowing in the analog V_{CC} and ground wires. The most effective method of accomplishing this is to use a single ground point and a single V_{CC} point where all wires are brought together. In addition to this the conductors must be of sufficient size to prevent significant voltage drops.

To prevent switching noise from causing jitter problems, a voltage regulator with good high frequency response is necessary. The LM309 and the LM340-5 voltage regulators both function well and are shown in *Figures 4, 5, and 6*. Adding more filtering than is shown will in general increase

the jitter rather than decrease it. The most important characteristic of transients on the V_{CC} line is the duration of the transient and not its amplitude.

Figure 4 shows a DPM system which converts 0V to 1.999V operating from a non-isolated power supply. In this configuration the sign output could be + (logic "1") or - (logic "0") and it should be ignored. Higher voltages could be converted by placing a fixed divider on the input; lower voltages could be converted by placing a fixed divider on the feedback, as shown in *Figure 6*.

Figures 5 and 6 show systems operating with an isolated supply that will convert positive and negative inputs. 60 Hz common mode input becomes a problem in this configuration and a transformer with an electrostatic shield between primary and secondary windings is shown. The necessity for using a shielded transformer depends on the performance requirements and the actual application.

The filter capacitors connected to V_{FB} (pin 14) and V_{FLT} (pin 11) should be low leakage. In the application examples shown every 1.0nA of leakage current will cause 0.1mV error ($1.0 \times 10^{-9}A \times 100k\Omega = 0.1mV$). If the leakage current in both capacitors is exactly the same no error will result since the source impedances driving them are matched.

TL/H/5681-6

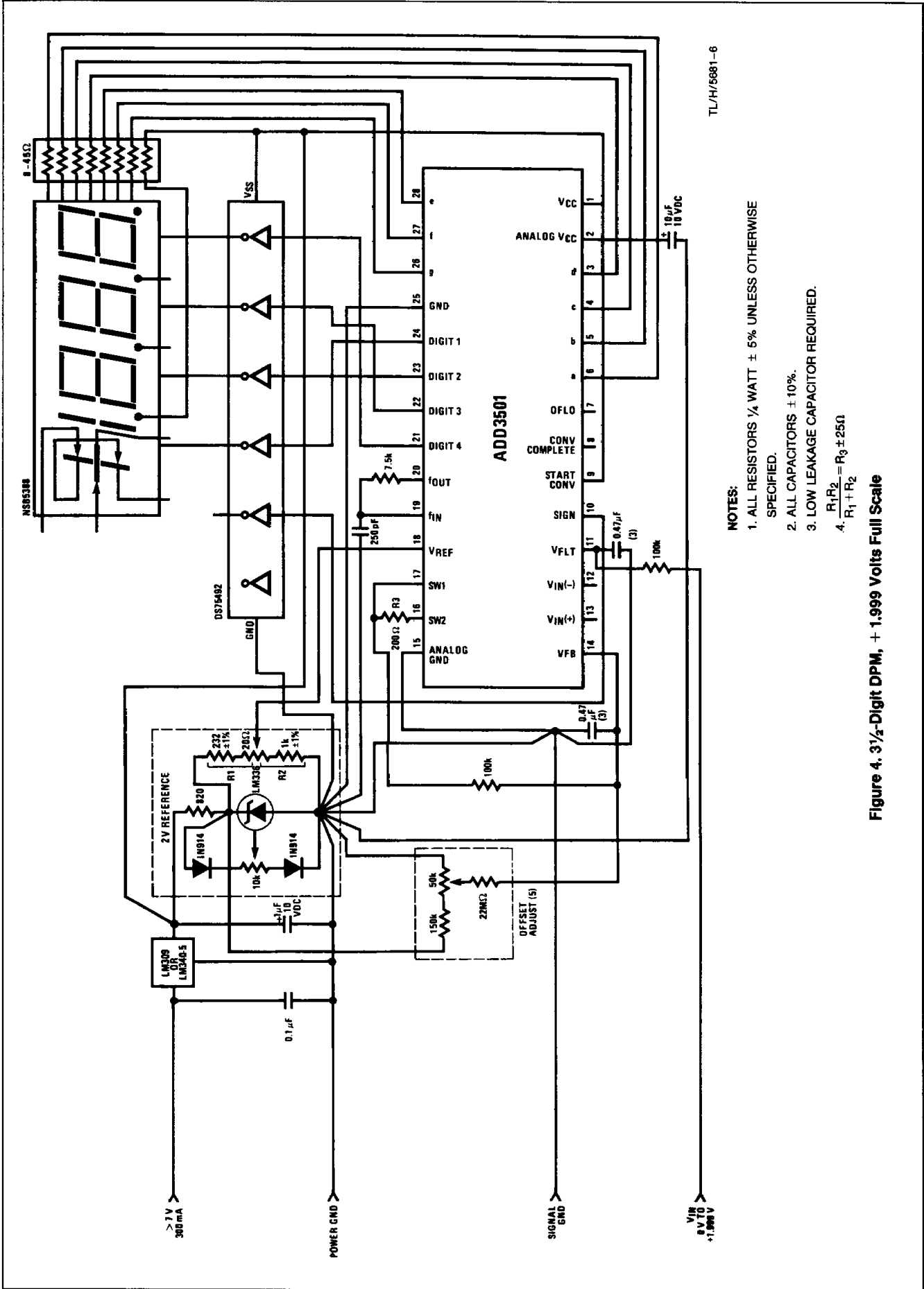

- NOTES:**
1. ALL RESISTORS 1/4 WATT ± 5% UNLESS OTHERWISE SPECIFIED.
 2. ALL CAPACITORS ± 10%.
 3. LOW LEAKAGE CAPACITOR REQUIRED.
 4. $\frac{R_1 R_2}{R_1 + R_2} = R_3 \pm 25\Omega$

Figure 4. 3 1/2-Digit DPM, + 1.999 Volts Full Scale

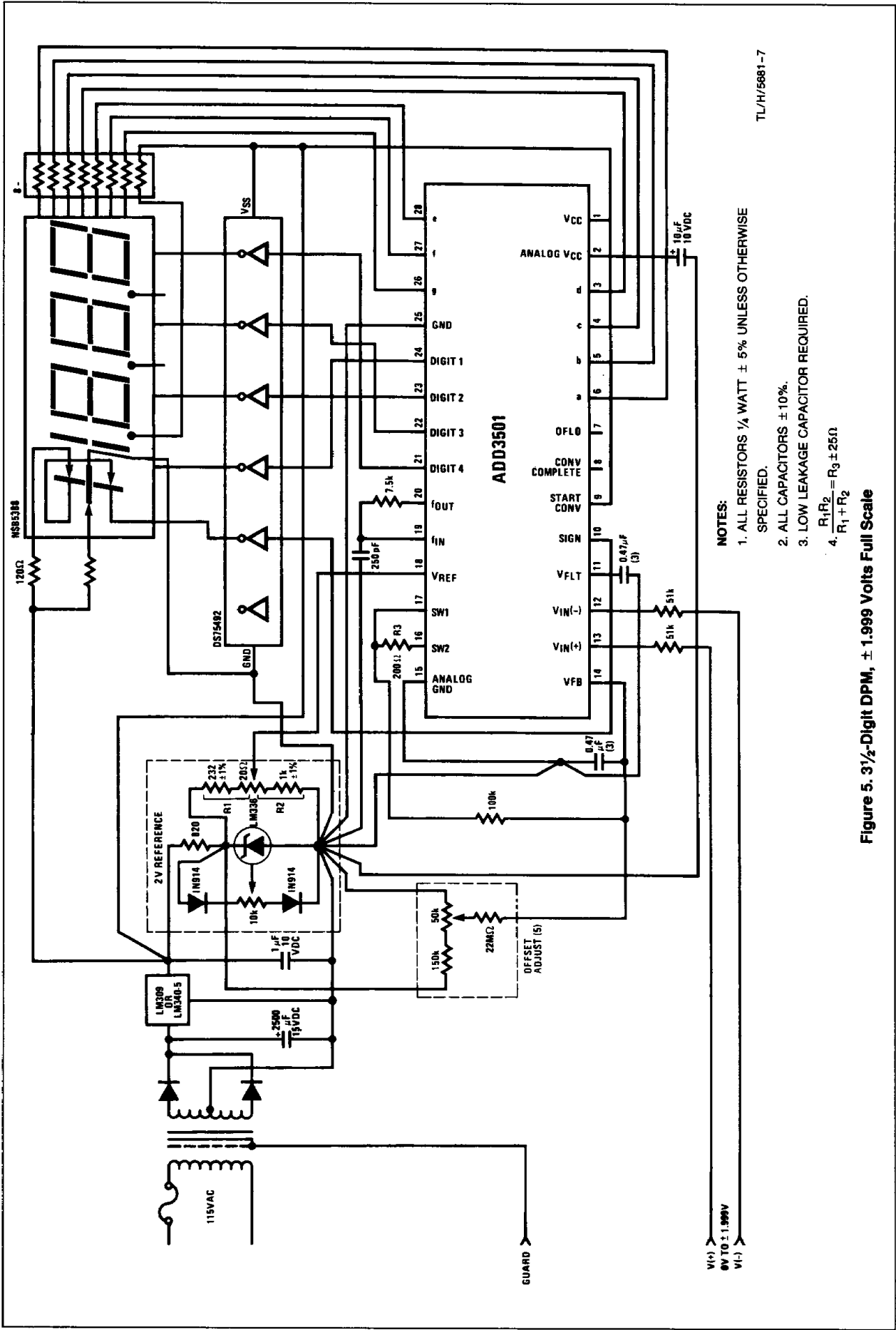

- NOTES:**
1. ALL RESISTORS 1/4 WATT ± 5% UNLESS OTHERWISE SPECIFIED.
 2. ALL CAPACITORS ± 10%.
 3. LOW LEAKAGE CAPACITOR REQUIRED.
 4. $R_1 R_2 = R_3 \pm 25\Omega$
 $R_1 + R_2$

Figure 5. 3 1/2-Digit DPM, ± 1.999 Volts Full Scale

TL/H/5681-7

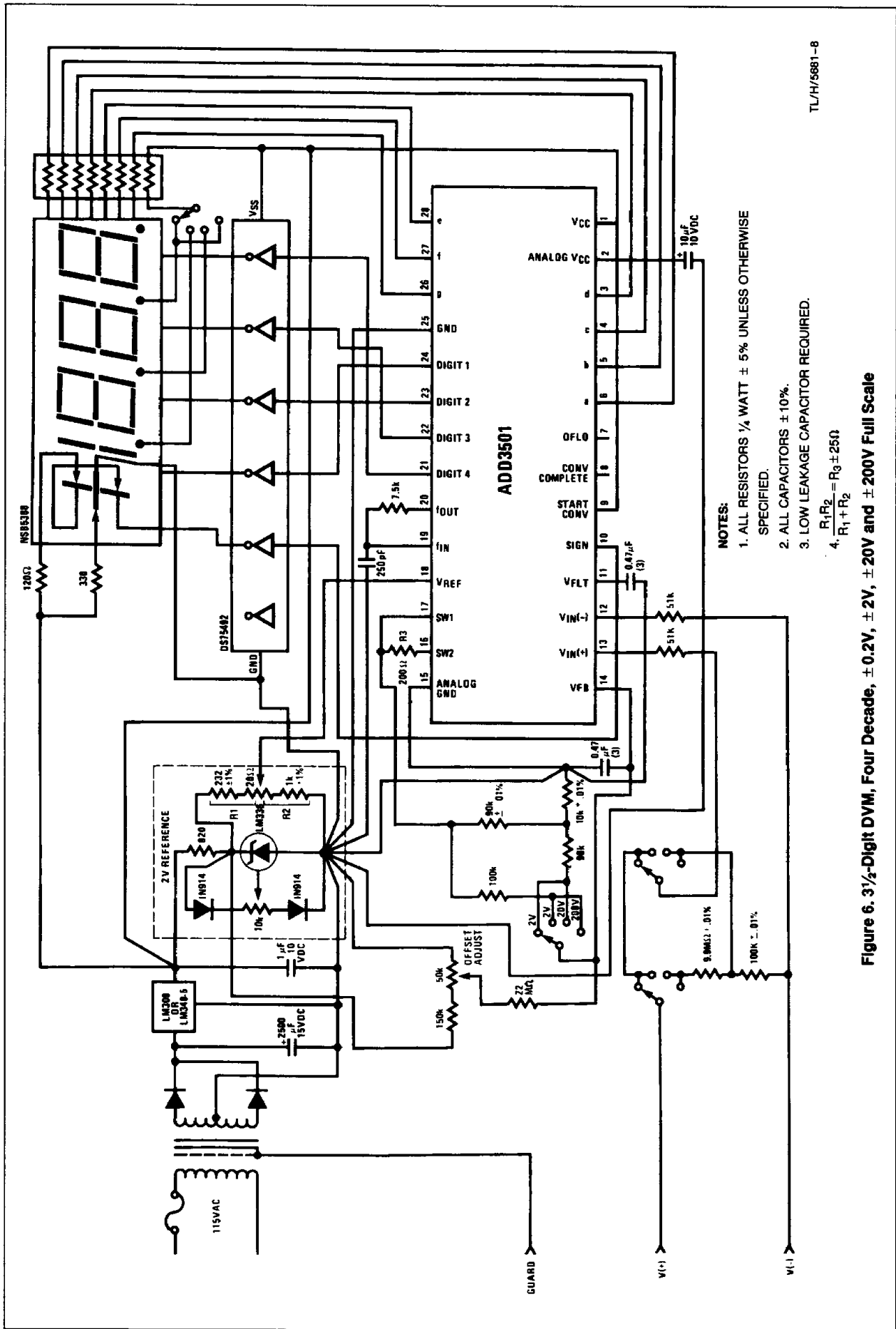

- NOTES:**
1. ALL RESISTORS 1/4 WATT ± 5% UNLESS OTHERWISE SPECIFIED.
 2. ALL CAPACITORS ± 10%.
 3. LOW LEAKAGE CAPACITOR REQUIRED.
 4. $\frac{R_1 R_2}{R_1 + R_2} = R_g \pm 250$

Figure 6. 3 1/2-Digit DVM, Four Decade, ± 0.2V, ± 2V, ± 20V and ± 200V Full Scale

TL/H/5681-8

ADD3501

