

FEATURES

- when used with the GS9005A or GS9015A and the GS9000B or GS9000S, the GS9010A:
 - constitutes an automatic 'tweakless' Serial Digital receiving system
 - eliminates the need for trim pots and external temperature compensation for bit rates to 370 Mb/s
 - automatically determines whether data is 4fsc or 4:2:2, and whether the 4fsc data is NTSC or PAL
 - acquires lock from a 'no signal' condition in typically 50 ms
 - holds lock during data interruptions for typically 2s
 - relocks from synchronous switching in less than 10 μs
- 16 pin SOIC packaging
- operates from a single +5 or -5 volt supply
- typically consumes only 40 mW
- immunity to spurious HSYNC inputs
- defines minimum GS9005A VCO frequency after extended absence of input signal
- matches GS9005A capture range

APPLICATIONS

- 4fsc, 4:2:2 & 360 Mb/s serial digital interfaces

ORDERING INFORMATION

Part Number	Package Type	Temperature Range
GS9010ACKC	16 Pin Wide SOIC	0° to 70° C
GS9010ACTC	16 Pin Wide SOIC Tape	0° to 70° C

DEVICE DESCRIPTION

The **GENLINX™** GS9010A is a monolithic integrated circuit designed to be an Automatic Tuning Subsystem (ATS) when used with the GS9005A Receiver or the GS9015A Reclocker and the GS9000B or GS9000S Decoder. The GS9010A ATS eliminates the need to manually set or externally temperature compensate the Receiver or Reclocker VCO. The GS9010A can also determine whether the incoming data stream is 4fsc NTSC, 4fsc PAL or component 4:2:2.

The GS9010A is an enhanced version of the GS9010. Pin compatible with the GS9010, the GS9010A offers improved noise immunity to spurious HSYNC signals.

The GS9010A includes a ramp generator/oscillator which repeatedly sweeps the Receiver/Reclocker VCO frequency over a set range until the system is correctly locked. Once locked, an automatic fine tuning (AFT) loop maintains the VCO control voltage at its optimum centre point over variations in temperature. During normal operation, the GS9000B or GS9000S Decoder provides continuous HSYNC pulses which disable the ramp/oscillator of the GS9010A. This maintains the correct Receiver/Reclocker VCO frequency. When an interruption to the incoming data stream is detected by the Receiver/Reclocker, the Carrier Detect goes LOW and opens the AFT loop in order to maintain the correct VCO frequency for a period of typically 2 seconds. If the signal is re-established within this 2 seconds, the Receiver/Reclocker will rapidly relock. For periods longer than typically 2 seconds, the VCO slowly drifts towards a minimum frequency. Typically after 2 minutes, the serial clock output of the PLL settles to approximately 85 MHz when $f/2$ is high or 170 MHz when $f/2$ is low. The GS9010A is packaged in a 16 pin wide SOIC, operates from a single +5 or -5 volt supply and typically consumes 40 mW of power.

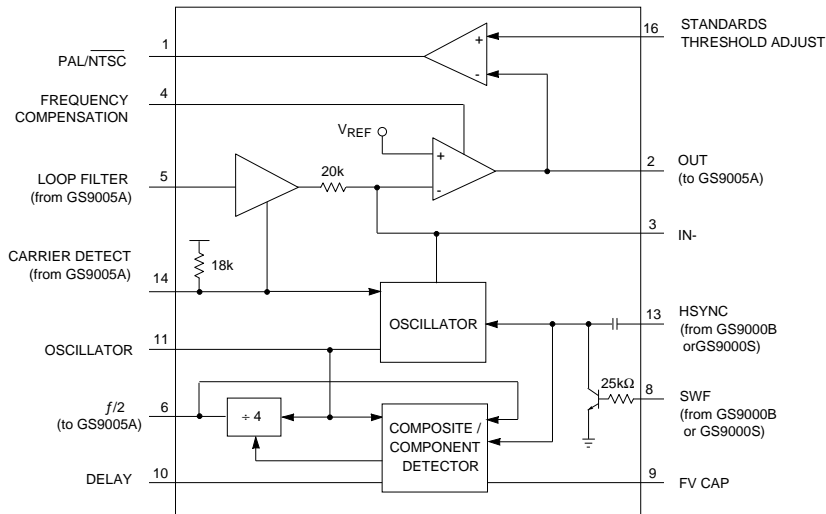

FUNCTIONAL BLOCK DIAGRAM

PIN CONNECTIONS

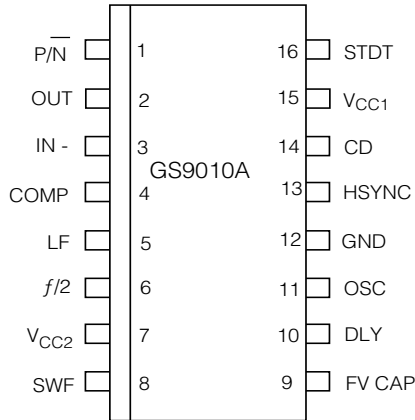

GS9010A PIN DESCRIPTIONS

PIN No.	SYMBOL	TYPE	DESCRIPTION
1	P/N	O	PAL/NTSC Output
2	OUT	O	Output to Receiver/Reclocker RVCO resistor
3	IN-	I	Inverting input to internal amplifier
4	COMP	I	Frequency compensating Capacitor
5	LF	I	Loop Filter input from Receiver/Reclocker
6	f/2	O	Divide by two output to Receiver/Reclocker
7	V _{CC}		Most positive supply voltage
8	SWF	I	Sync Warning Flag Input from GS9000B or GS9000S
9	FV CAP	I	Capacitor for frequency to voltage converter
10	DLY	I	Capacitor for internal delay
11	OSC	I	RC time constant for internal oscillator
12	GND		Most negative supply voltage
13	HSYNC	I	HSYNC input from GS9000B or GS9000S Decoder
14	CD	I	Carrier Detect input from Receiver/Reclocker
15	V _{CC}		Most positive supply voltage
16	STDT	I	Standards threshold adjust input from external potentiometer

ABSOLUTE MAXIMUM RATINGS

Parameter	Value/Units
Supply Voltage	±5.5 V
Input Voltage Range (any input)	-V _{EE} < V _I < V _{CC}
DC Input Current (any one input)	10mA
Operating Temperature Range	0°C ≤ T _A ≤ 70°C
Storage Temperature Range	-65°C ≤ T _S ≤ 150°C
Lead Temperature (soldering, 10 seconds)	260°C

GS9010A DC ELECTRICAL CHARACTERISTICS

(V_{CC} = 5 V, T_A = 0° C to 70° C, unless otherwise specified)

PARAMETER	SYMBOL	CONDITIONS	MIN	TYP	MAX	UNITS
Supply Voltage	V _S		4.75	5.0	5.25	V
Supply Current	I _S		5.5	8.0	10.0	mA
OUT Voltage Maximum	V _{OUT MAX}	V _{LF} = 2.7 V	2.2	2.3	2.4	V
LF Input Bias	I _{LF}	V _{LF} = 2.3 V	-10	0	10	nA
IN Input Bias	I _{IN}	CD Low	0	5	70	nA
STDT Input Bias	I _{STDT}	V _{STDT} = 1.5 V	-10	-0.5	0	μA
STDT Input Voltage	V _{STDT}		0	-	3	V
CD Input Pull-Up Resistor	R _{CD}		13.5	18	22.5	kΩ
P/N Low-Level Output Voltage	V _{P/NL}	I _L = 0	-	-	0.2	V
P/N Low-Level Output Current	I _{P/NL}		-1	-	-	mA
P/N Output Pull-Up Resistor			-	30	-	kΩ
f/2 High-Level Output Voltage	V _{f/2H}	I _L = 0	4	4.6	-	V
f/2 Low-Level Output Voltage	V _{f/2L}	I _L = 0	-	-	0.2	V
f/2 Output Current	I _{f/2}		-	±40	-	μA
SWF Input Bias	I _{SWF}	V _{SWF} = 5 V	150	200	250	μA

GS9010A AC ELECTRICAL CHARACTERISTICS

(V_{CC} = 5 V, T_A = 0° C to 70° C, unless otherwise specified)

PARAMETER	SYMBOL	CONDITIONS	MIN	TYP	MAX	UNITS
HSYNC Input Frequency for f/2 High	f _{COMPOSITE}	V _{CC} = 4.75 to 5.25	-	7.85	11.0	kHz
HSYNC Input Frequency for f/2 Low	f _{COMPONENT}	V _{CC} = 4.75 to 5.25	11.0	15.7	-	kHz
HSYNC Input Rise / Fall Time	tr _{HSYNC}	CMOS Driving Levels	-	-	100	ns

SYSTEM DESCRIPTION

The GS9005A Receiver or GS9015A Reclocker along with the GS9000B or GS9000S Decoder form a serial to parallel decoding system for Serial Digital Video signals. Use of the GS9010A eliminates the need to manually tune the VCO and externally temperature compensate for all data rates. Figure 1 shows a simplified block diagram of the Automatic Tuning Sub-System and Figure 2 shows the relevant waveforms.

The active high CARRIER DETECT output of the Receiver/Reclocker indicates the presence of serial data. If the CARRIER DETECT input to the GS9010A (pin 14) is HIGH (see Fig 2. [A]) and a Timing Reference Signal (TRS) is not being detected by the GS9000B or GS9000S Decoder, an oscillator in the GS9010A produces a sawtooth ramp signal at the OUT pin (pin 2) (see Figure 2. [C]). This output is connected to the Receiver/Reclocker R_{VCO} pin via a resistor which converts this voltage ramp into a current ramp. The frequency of the VCO is changed by varying the current drawn from the R_{VCO} pin such that a lower sweep voltage at pin 2 of the GS9010A causes a higher VCO frequency.

As the frequency sweeps, the PLL will lock to the incoming data stream and the GS9000B or GS9000S decoder will detect TRS. The TRS detect function is provided by the HSYNC output of the GS9000B or GS9000S. In this case, HSYNC is a digital signal which changes state whenever TRS is detected. This signal is connected to the HSYNC input (pin 13) of the GS9010A (see Figure 2 [B]). This signal will be at a rate equal to one half the horizontal scan rate for composite video and equal to the horizontal scan rate for component video since both EAV and SAV produce an HSYNC state change. The presence of detected TRS will shut off the GS9010A oscillator and disable the sweep. Even though the oscillator is off, the Automatic Fine Tuning (AFT) function provided by the buffer amplifier in the GS9010A remains in the control loop in order to centre the GS9005A or GS9015A loop filter voltage to V_{REF} (approximately 2.3V).

The VCO within the GS9005A or GS9015A has a dual modulus divider feature which optimises jitter performance for the lower data rates. This feature is enabled by a logic HIGH on the $f/2$ pin. The MODULUS CONTROL output (pin 6) (see Figure 2. [D]) of the GS9010A controls this $f/2$ function to set the VCO frequency to twice the normal rate. Under normal operation the VCO within the GS9005A or GS9015A, operates at twice the output clock frequency, which means that for 360 Mb/s data the VCO is operating at 720 MHz (2×360 MHz). For 177 Mb/s (PAL - 4fsc), with the $f/2$ function enabled, the VCO operates at 708 MHz ($2 \times 2 \times 177$ MHz). In the case of component and composite NTSC, the VCO operates at 540 MHz (2×270 MHz) and 572 MHz ($2 \times 2 \times 143$ MHz) respectively. This means that the VCO is tuned to the same frequency range for 4:2:2 and the respective 4fsc signals.

The MODULUS CONTROL itself is derived by dividing the GS9010A oscillator by four. It is possible that the PLL could lock with the MODULUS CONTROL in the wrong state ($f/2$ OFF) for component data rates.

In order to avoid this, another circuit ensures that the MODULUS CONTROL is set HIGH ($f/2$ ENABLED) for composite data rates and LOW ($f/2$ OFF) for component data rates. This is accomplished through a Frequency Detector (Frequency to Voltage Converter, FVC) which measures the frequency of HSYNC and compares it to a reference. If the frequency of HSYNC corresponds to composite video, the comparator output is high and the $\div 4$ (MODULUS CONTROL) is set HIGH. Conversely, when the frequency of HSYNC corresponds to component video, the MODULUS CONTROL is set LOW.

If the FVC measurement results in any change to the MODULUS CONTROL, the PLL will immediately lose lock, the TRS will not be detected and the oscillator will begin to sweep the VCO frequency. Now the PLL will reacquire lock with the MODULUS CONTROL in the correct state before the $\div 4$ output changes state.

In a noisy environment or at power-on, erratic TRS will cause the GS9000B or GS9000S to output an artificially low HSYNC frequency. This condition often subsides after input data stabilizes or in the case of power-up, once the supplies have settled. The GS9010A employs a technique to provide noise immunity within the COMPOSITE/COMPONENT DETECTOR (CCD) to protect against erroneous modulus settings. This technique is explained in the following paragraph.

A delay is required for the FVC calculation within the CCD before the $\div 4$ is set/reset. In the GS9010A, the trigger threshold for this delay is controlled by the $f/2$ and FVCAP output voltage. Because this threshold is modulated, the incoming HSYNC frequency must be compatible with the current $f/2$ state before the delay is triggered. This threshold control prevents artificially low HSYNC frequencies from triggering the set/reset of the $\div 4$ thus preventing the wrong MODULUS CONTROL.

If the serial digital signal is interrupted, CARRIER DETECT (pin 14) goes LOW and turns the internal oscillator off. The buffer from the LOOP FILTER input (pin 5) to the 20 k Ω integrator resistor is disabled and its output becomes high impedance, neither sinking nor sourcing current. In this state, the output voltage from the GS9010A will remain constant for a time period of typically 2 seconds. The VCO in the Receiver/Reclocker will remain tuned to the correct frequency so that the PLL will relock quickly without frequency sweeping when the serial data returns. For longer periods of data interruption, the external integration capacitor between the OUT and IN pins will slowly discharge and the VCO will drift lower in frequency. The serial clock output frequency of the PLL will settle to approximately 170 MHz when $f/2$ is high and 85 MHz when $f/2$ is low. A limit has been set on the maximum OUT voltage to prevent Receiver/Reclocker VCO shutdown allowing faster relock time once data is reapplied.

PAL/NTSC THRESHOLD ADJUST

To adjust the P/N threshold using a potentiometer, monitor the OUT voltage at pin 2 of the GS9010A. Start with a composite NTSC source, and record the voltage at pin 2 as V_{NTSC} . Now connect a PAL source to the input and record the voltage at pin 2 as V_{PAL} . Adjust the reference voltage, V_{REF} at pin 16 to a value approximately halfway between V_{PAL} and V_{NTSC} , i.e. $V_{REF} = (V_{NTSC} + V_{PAL})/2$. The P/N threshold will now be set.

Gating of the HSYNC input is available on the SWF pin. This gating is used with the GS9010A to improve immunity to missing TRS detection during power-up or in noisy system applications.

Capacitor values for the GS9010A should be used as indicated in Figure 3. These capacitors have been optimised to produce correct system operation.

GS9010 REPLACEMENT NOTE:

To ensure proper operation of the GS9010A, the resistor network connected between the GS9010A OUT (pin 2) and GS9005A RVC03 (pin 17), and the value of FVCAP (pin 9) must be as per this data sheet (Figure 3). Replacing a GS9010 with a GS9010A will require modification to these component values.

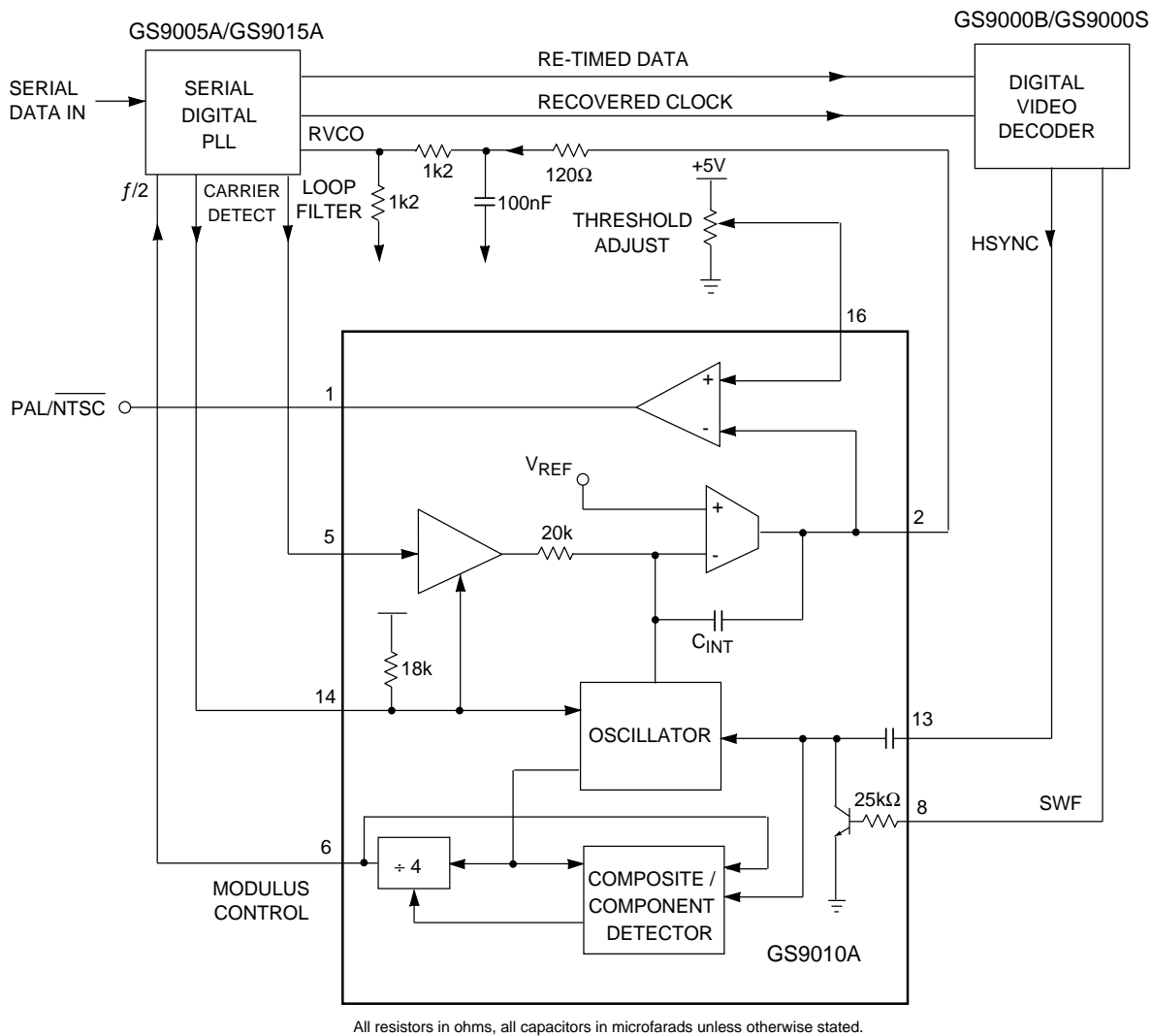

Fig. 1 Automatic Tuning Sub System Block Diagram

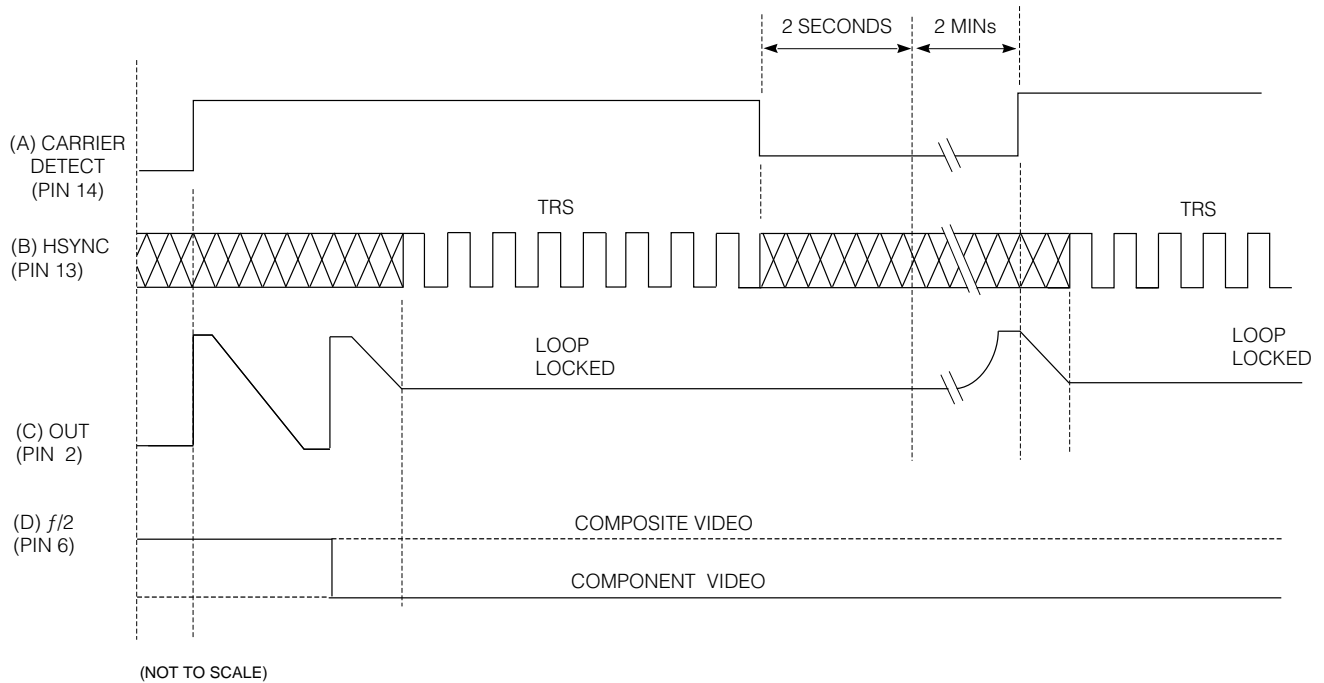

Fig. 2 System Waveform Diagrams

APPLICATIONS

Figure 3 shows a typical application circuit using the GS9010A in an autotuning SDI receiver.

Correct operation of an autotuning receiver is determined by using a suitable EDH measurement tool or Digital to Analog Monitor to verify error free performance.

The correct operation of a locked autotuning receiver can be verified by referring to Figure 2. The HSYNC output from the GS9000B or GS9000S decoder will toggle on each occurrence of the Timing Reference Signal (TRS). The state of the HSYNC output is not significant, just the rate at which it toggles.

Application Note - PCB Layout

Special attention must be paid to component layout when designing high performance serial digital receivers.

For background information on high speed circuit and layout design concepts, refer to Document No. 521-32-00, "Optimizing Circuit and Layout Design of the GS90005A/15A". A recommended PCB layout can be found in the Gennum Application Note "EB9010B Deserializer Evaluation Board"

The use of a star grounding technique is required for the loop filter components of the GS9005A/15A.

Controlled impedance PCB traces should be used for the differential clock and data interconnection between the GS9005A and the GS9000B or GS9000S. These differential traces must not pass over any ground plane discontinuities. A slot antenna is formed when a microstrip trace runs across a break in the ground plane.

The series resistors at the parallel data output of the GS9000B/S are used to slow down the fast rise/fall time of the GS9000B/S outputs. These resistors should be placed as close as possible to the GS9000B or GS9000S output pins to minimize radiation from these pins.

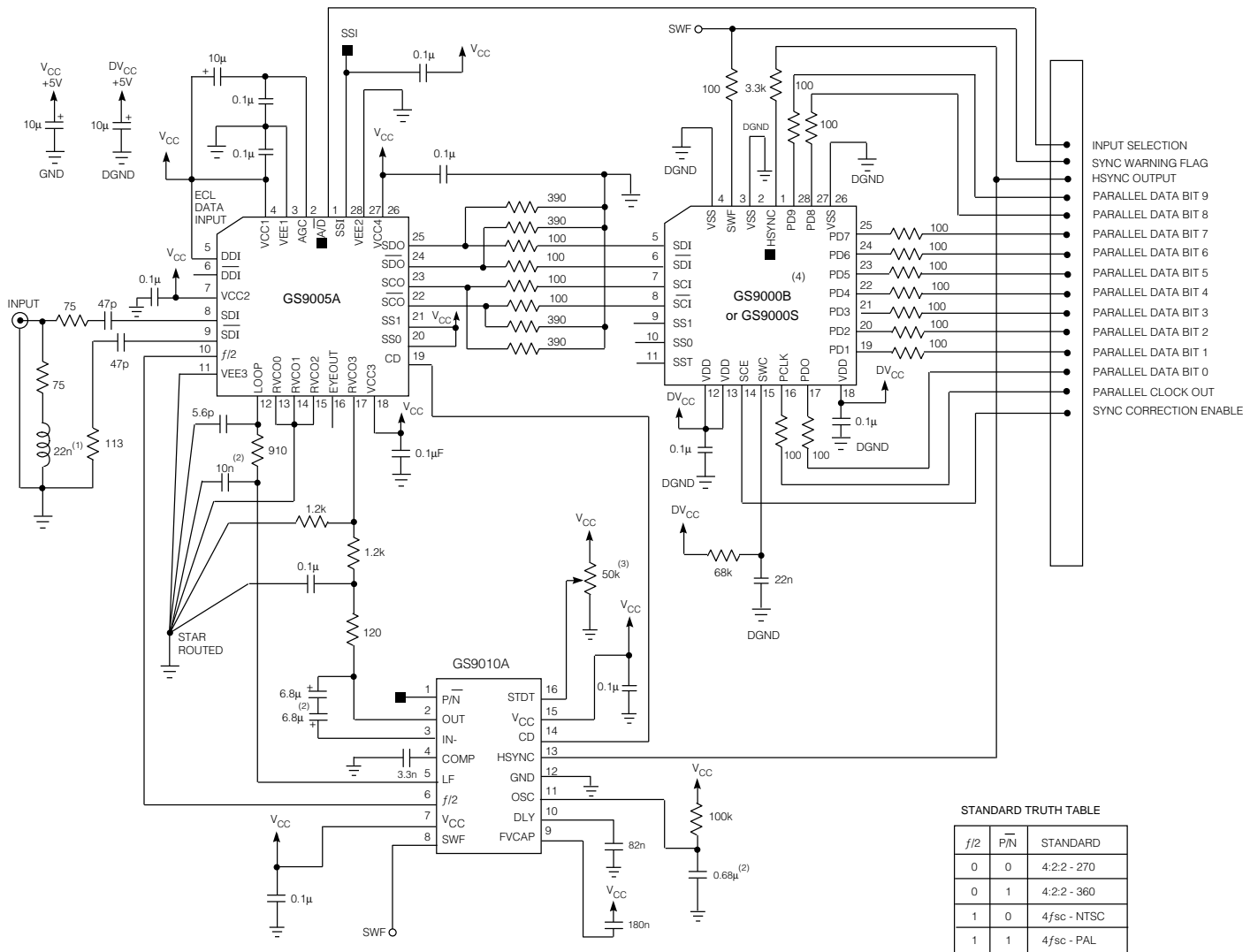

All resistors in ohms, all capacitors in microfarads, all inductors in henries unless otherwise stated.

- (1) Typical value for input return loss matching
- (2) To reduce board space, the two anti-series 6.8 μ F capacitors (connected across pins 2 and 3 of the GS9010A) may be replaced with a 1.0 μ F non-polarized capacitor provided that:
 - (a) the 0.68 μ F capacitor connected to the OSC pin (11) of the GS9010A is replaced with a 0.33 μ F capacitor and
 - (b) the GS9005A /15A Loop Filter Capacitor is 10 nF.
- (3) Remove this potentiometer if P/N function is not required, and ground pin 16 of the GS9010A.
- (4) The GS9000B will operate to a maximum frequency of 370 Mbps.
The GS9000S will operate to a maximum frequency of 300 Mbps.

Fig. 3 Typical Application Circuit

REVISION NOTES
Figures 1 and 3 updated

CAUTION
ELECTROSTATIC
SENSITIVE DEVICES
DO NOT OPEN PACKAGES OR HANDLE
EXCEPT AT A STATIC-FREE WORKSTATION



DOCUMENT IDENTIFICATION

PRODUCT PROPOSAL
This data has been compiled for market investigation purposes only, and does not constitute an offer for sale.

ADVANCE INFORMATION NOTE
This product is in development phase and specifications are subject to change without notice. Gennum reserves the right to remove the product at any time. Listing the product does not constitute an offer for sale.

PRELIMINARY
The product is in a preproduction phase and specifications are subject to change without notice.

DATA SHEET
The product is in production. Gennum reserves the right to make changes at any time to improve reliability, function or design, in order to provide the best product possible.