

# 14-Stage Binary Ripple Counter

## High-Performance Silicon-Gate CMOS

The MC54/74HC4020 is identical in pinout to the standard CMOS MC14020B. The device inputs are compatible with standard CMOS outputs; with pullup resistors, they are compatible with LSTTL outputs.

This device consists of 14 master-slave flip-flops with 12 stages brought out to pins. The output of each flip-flop feeds the next and the frequency at each output is half that of the preceding one. The state of the counter advances on the negative-going edge of the Clock input. Reset is asynchronous and active-high.

State changes of the Q outputs do not occur simultaneously because of internal ripple delays. Therefore, decoded output signals are subject to decoding spikes and may have to be gated with the Clock of the HC4020 for some designs.

- Output Drive Capability: 10 LSTTL Loads
- Outputs Directly Interface to CMOS, NMOS, and TTL
- Operating Voltage Range: 2 to 6 V
- Low Input Current: 1  $\mu$ A
- High Noise Immunity Characteristic of CMOS Devices
- In Compliance with the Requirements Defined by JEDEC Standard No. 7A
- Chip Complexity: 398 FETs or 99.5 Equivalent Gates

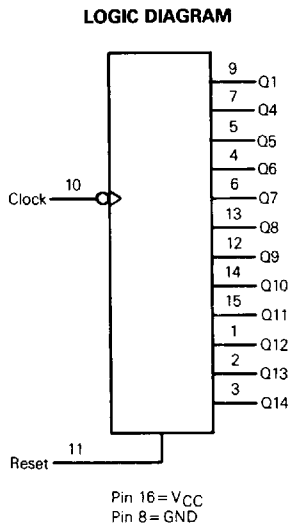

### MC54/74HC4020

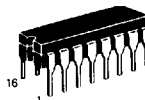

**J SUFFIX  
 CERAMIC  
 CASE 620-09**



**N SUFFIX  
 PLASTIC  
 CASE 648-08**

#### ORDERING INFORMATION

MC74HCXXXXN Plastic  
 MC54HCXXXXJ Ceramic

T<sub>A</sub> = -55° to 125°C for all packages.  
 Dimensions in Chapter 6.

#### PIN ASSIGNMENT

Q12	1	16	V <sub>CC</sub>
Q13	2	15	Q11
Q14	3	14	Q10
Q6	4	13	Q8
Q5	5	12	Q9
Q7	6	11	Reset
Q4	7	10	Clock
GND	8	9	Q1

#### FUNCTION TABLE

Clock	Reset	Output State
	L	No Change
	L	Advance to next state
X	H	All Outputs are low

5

## MAXIMUM RATINGS\*

Symbol	Parameter	Value	Unit
V <sub>CC</sub>	DC Supply Voltage (Referenced to GND)	-0.5 to +7.0	V
V <sub>in</sub>	DC Input Voltage (Referenced to GND)	-1.5 to V <sub>CC</sub> +1.5	V
V <sub>out</sub>	DC Output Voltage (Referenced to GND)	-0.5 to V <sub>CC</sub> +0.5	V
I <sub>in</sub>	DC Input Current, per Pin	±20	mA
I <sub>out</sub>	DC Output Current, per Pin	±25	mA
I <sub>CC</sub>	DC Supply Current, V <sub>CC</sub> and GND Pins	±50	mA
P <sub>D</sub>	Power Dissipation in Still Air, Plastic or Ceramic DIP†	750	mW
T <sub>stg</sub>	Storage Temperature	-65 to +150	°C
T <sub>L</sub>	Lead Temperature, 1 mm from Case for 10 Seconds (Plastic DIP) (Ceramic DIP)	260 300	°C

This device contains protection circuitry to guard against damage due to high static voltages or electric fields. However, precautions must be taken to avoid applications of any voltage higher than maximum rated voltages to this high-impedance circuit. For proper operation, V<sub>in</sub> and V<sub>out</sub> should be constrained to the range GND ≤ (V<sub>in</sub> or V<sub>out</sub>) ≤ V<sub>CC</sub>.

Unused inputs must always be tied to an appropriate logic voltage level (e.g., either GND or V<sub>CC</sub>). Unused outputs must be left open.

\*Maximum Ratings are those values beyond which damage to the device may occur. Functional operation should be restricted to the Recommended Operating Conditions.

†Derating — Plastic DIP: -10 mW/°C from 65° to 125°C

Ceramic DIP: -10 mW/°C from 100° to 125°C

For high frequency or heavy load considerations, see Chapter 4.

## RECOMMENDED OPERATING CONDITIONS

Symbol	Parameter	Min	Max	Unit
V <sub>CC</sub>	DC Supply Voltage (Referenced to GND)	2.0	6.0	V
V <sub>in</sub> , V <sub>out</sub>	DC Input Voltage, Output Voltage (Referenced to GND)	0	V <sub>CC</sub>	V
T <sub>A</sub>	Operating Temperature, All Package Types	-55	+125	°C
t <sub>r</sub> , t <sub>f</sub>	Input Rise and Fall Time (Figure 1)	V <sub>CC</sub> =2.0 V V <sub>CC</sub> =4.5 V V <sub>CC</sub> =6.0 V	0 1000 500 400	ns

## DC ELECTRICAL CHARACTERISTICS (Voltages Referenced to GND)

Symbol	Parameter	Test Conditions	V <sub>CC</sub> V	Guaranteed Limit			Unit
				25°C to -55°C	≤85°C	≤125°C	
V <sub>IH</sub>	Minimum High-Level Input Voltage	V <sub>out</sub> =0.1 V or V <sub>CC</sub> -0.1 V  I <sub>out</sub>   ≤ 20 μA	2.0	1.5	1.5	1.5	V
			4.5	3.15	3.15	3.15	
			6.0	4.2	4.2	4.2	
V <sub>IL</sub>	Maximum Low-Level Input Voltage	V <sub>out</sub> =0.1 V or V <sub>CC</sub> -0.1 V  I <sub>out</sub>   ≤ 20 μA	2.0	0.3	0.3	0.3	V
			4.5	0.9	0.9	0.9	
			6.0	1.2	1.2	1.2	
V <sub>OH</sub>	Minimum High-Level Output Voltage	V <sub>in</sub> = V <sub>IH</sub> or V <sub>IL</sub>  I <sub>out</sub>   ≤ 20 μA	2.0	1.9	1.9	1.9	V
			4.5	4.4	4.4	4.4	
		V <sub>in</sub> = V <sub>IH</sub> or V <sub>IL</sub>  I <sub>out</sub>   ≤ 4.0 mA  I <sub>out</sub>   ≤ 5.2 mA	6.0	5.9	5.9	5.9	
			4.5	3.98	3.84	3.70	
V <sub>OL</sub>	Maximum Low-Level Output Voltage	V <sub>in</sub> = V <sub>IH</sub> or V <sub>IL</sub>  I <sub>out</sub>   ≤ 20 μA	2.0	0.1	0.1	0.1	V
			4.5	0.1	0.1	0.1	
		V <sub>in</sub> = V <sub>IH</sub> or V <sub>IL</sub>  I <sub>out</sub>   ≤ 4.0 mA  I <sub>out</sub>   ≤ 5.2 mA	6.0	0.1	0.1	0.1	
			4.5	0.26	0.33	0.40	
I <sub>in</sub>	Maximum Input Leakage Current	V <sub>in</sub> = V <sub>CC</sub> or GND	6.0	±0.1	±1.0	±1.0	μA
			2.0	±0.1	±1.0	±1.0	
I <sub>CC</sub>	Maximum Quiescent Supply Current (per Package)	V <sub>in</sub> = V <sub>CC</sub> or GND I <sub>out</sub> = 0 μA	6.0	8	80	160	μA
			2.0	8	80	160	

NOTE: Information on typical parametric values can be found in Chapter 4.

AC ELECTRICAL CHARACTERISTICS ( $C_L = 50$  pF, Input  $t_r = t_f = 6$  ns)

Symbol	Parameter	V <sub>CC</sub> V	Guaranteed Limit			Unit
			25°C to -55°C	≤85°C	≤125°C	
f <sub>max</sub>	Maximum Clock Frequency (50% Duty Cycle) (Figures 1 and 4)	2.0	5.0	4.0	3.4	MHz
		4.5	25	20	17	
		6.0	29	24	20	
t <sub>PLH</sub> , t <sub>PHL</sub>	Maximum Propagation Delay, Clock to Q1* (Figures 1 and 4)	2.0	210	265	315	ns
		4.5	42	53	63	
		6.0	36	45	54	
t <sub>PHL</sub>	Maximum Propagation Delay, Reset to Any Q (Figures 2 and 4)	2.0	240	300	360	ns
		4.5	48	60	72	
		6.0	41	51	61	
t <sub>PLH</sub> , t <sub>PHL</sub>	Maximum Propagation Delay, Q <sub>N</sub> to Q <sub>N+1</sub> (Figures 3 and 4)	2.0	125	155	190	ns
		4.5	25	31	38	
		6.0	21	26	32	
t <sub>TLH</sub> , t <sub>THL</sub>	Maximum Output Transition Time, Any Output (Figures 1 and 4)	2.0	75	95	110	ns
		4.5	15	19	22	
		6.0	13	16	19	
C <sub>in</sub>	Maximum Input Capacitance	—	10	10	10	pF

## NOTES:

- For propagation delays with loads other than 50 pF, see Chapter 4.
- Information on typical parametric values can be found in Chapter 4.

\*For T<sub>A</sub> = 25°C and C<sub>L</sub> = 50 pF, typical propagation delay from Clock to other Q outputs may be calculated with the following equations:

$$V_{CC} = 2.0 \text{ V: } t_p = [205 + 107.5(N - 1)] \text{ ns}$$

$$V_{CC} = 4.5 \text{ V: } t_p = [41 + 21.5(N - 1)] \text{ ns}$$

$$V_{CC} = 6.0 \text{ V: } t_p = [35 + 18.3(N - 1)] \text{ ns}$$

C <sub>PD</sub>	Power Dissipation Capacitance (Per Package) Used to determine the no-load dynamic power consumption: $P_D = C_{PD} V_{CC}^2 f + I_{CC} V_{CC}$ For load considerations, see Chapter 4.	Typical @ 25°C, V <sub>CC</sub> = 5.0 V	pF
		30	

TIMING REQUIREMENTS (Input  $t_r = t_f = 6$  ns)

Symbol	Parameter	V <sub>CC</sub> V	Guaranteed Limit			Unit
			25°C to -55°C	≤85°C	≤125°C	
t <sub>rec</sub>	Minimum Recovery Time, Reset Inactive to Clock (Figure 2)	2.0	100	125	150	ns
		4.5	20	25	30	
		6.0	17	21	26	
t <sub>w</sub>	Minimum Pulse Width, Clock (Figure 1)	2.0	80	100	120	ns
		4.5	16	20	24	
		6.0	14	17	20	
t <sub>w</sub>	Minimum Pulse Width, Reset (Figure 2)	2.0	80	100	120	ns
		4.5	16	20	24	
		6.0	14	17	20	
t <sub>r</sub> , t <sub>f</sub>	Maximum Input Rise and Fall Times (Figure 1)	2.0	1000	1000	1000	ns
		4.5	500	500	500	
		6.0	400	400	400	

NOTE: Information on typical parametric values can be found in Chapter 4.

PIN DESCRIPTIONS

INPUTS

**CLOCK (PIN 10)** — Negative-edge triggering clock input. A high-to-low transition on this input advances the state of the counter.

**RESET (PIN 11)** — Active-high reset. A high level applied

to this input asynchronously resets the counter to its zero state, thus forcing all Q outputs low.

OUTPUTS

**Q1, Q4—Q14 (PINS 9, 7, 5, 4, 6, 13, 12, 14, 15, 1, 2, 3)** — Active-high outputs. Each QN output divides the Clock input frequency by  $2^N$ .

SWITCHING WAVEFORMS

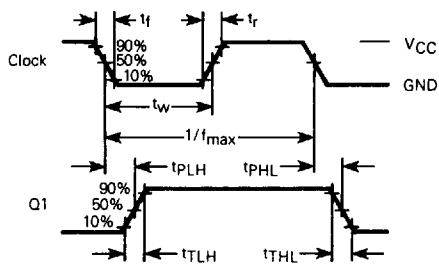

Figure 1.

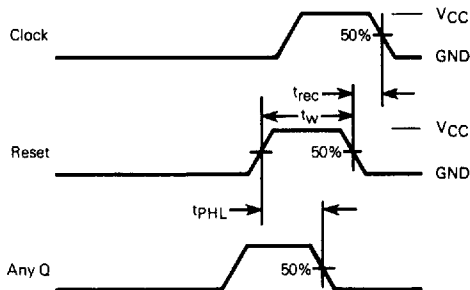

Figure 2.

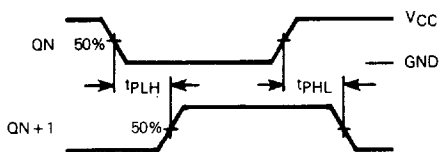
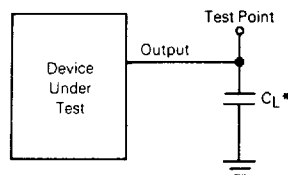

Figure 3.



\*Includes all probe and jig capacitance.

Figure 4. Test Circuit

EXPANDED LOGIC DIAGRAM

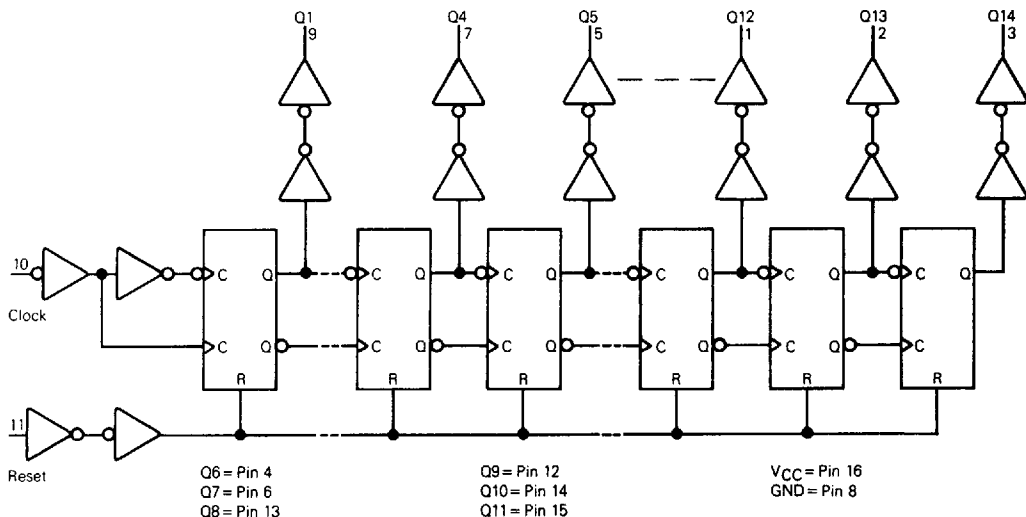

## TIMING DIAGRAM

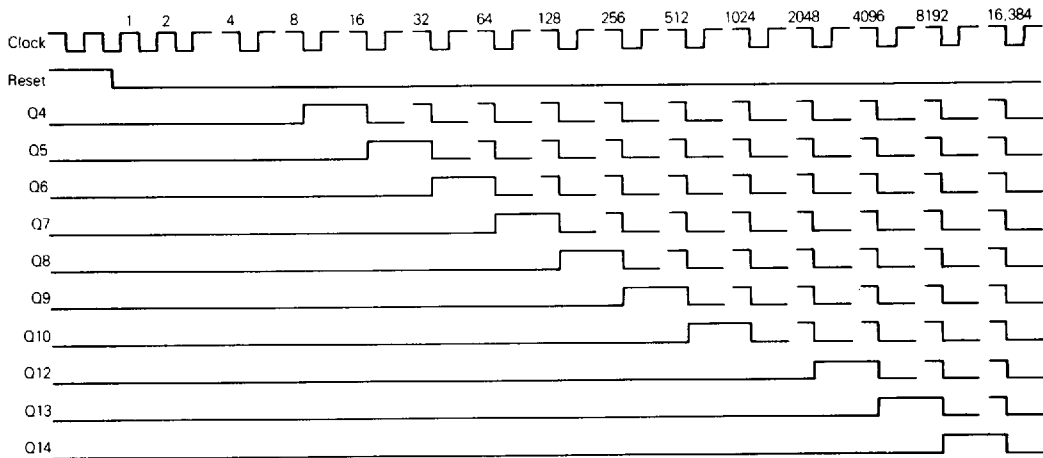

## APPLICATIONS INFORMATION

## TIME-BASE GENERATOR

A 60 Hz sinewave obtained through a 1.0 Megohm resistor connected directly to a standard 120 Vac power line is applied to the input of the MC54/74HC14, Schmitt-trigger inverter. The HC14 squares-up the input waveform and feeds the

HC4020. Selecting outputs Q5, Q10, Q11, and Q12 causes a reset every 3600 clocks. The HC20 decodes the counter outputs, produces a single (narrow) output pulse, and resets the binary counter. The resulting output frequency is 1.0 pulse/minute.

